

MoNo Clipper

The MoNo Clipper packaging machine uses a PE label to seal the tubular net. It has an automatic tube changer that enables a continuous supply of net. This variant is more durable and requires less maintenance than the conventional Clipper because it doesn't need a clip magazine or oil. The integrated labeler supports strip, wine glass, and seal-to-seal labels.

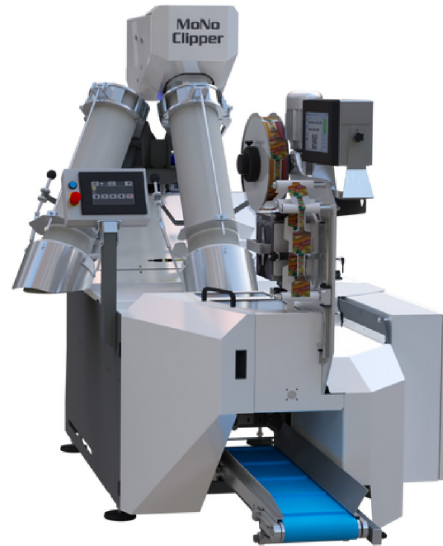

FEATURES

- The packaging machine for the tubular net is closed with a seal using a PE label
- Mono material bags that are easy to recycle
- Accepts both extruded and knitted mesh materials
- Integrated labeler works with both wine glass and strip labels and can easily switch for different packages
- Automatic tube exchange to continue operation while tube netting is refilled

ADDITIONAL OPTIONS

- Thermo bar-code printers
- Net ruckers
- Intermittent discharge conveyor

PARTNER OPTIONS

- M8
- MD12
- MD16
- MD20 D
- M10
- M12V
- MD16 D
- M2i V

PACKAGE SIZE RANGE

- ½ to 4 pounds

PACKAGE DIMENSION

Tube Netting Diameter

- Min 6.3" (160mm)
- Max 7.9" (200mm)

CAPACITY / RATE

- 2 pounds up to 30 packages per minute*

AIR CONSUMPTION

- 1.8 CFM**

POWER

- 230 Volt, 3 phase and ground

MOST COMMON PRODUCTS

- Onions
- Citrus Fruits
- Potatoes
- Garlic & Shallots
- Nuts

Custom testing is available for any product.

MoNo Clipper

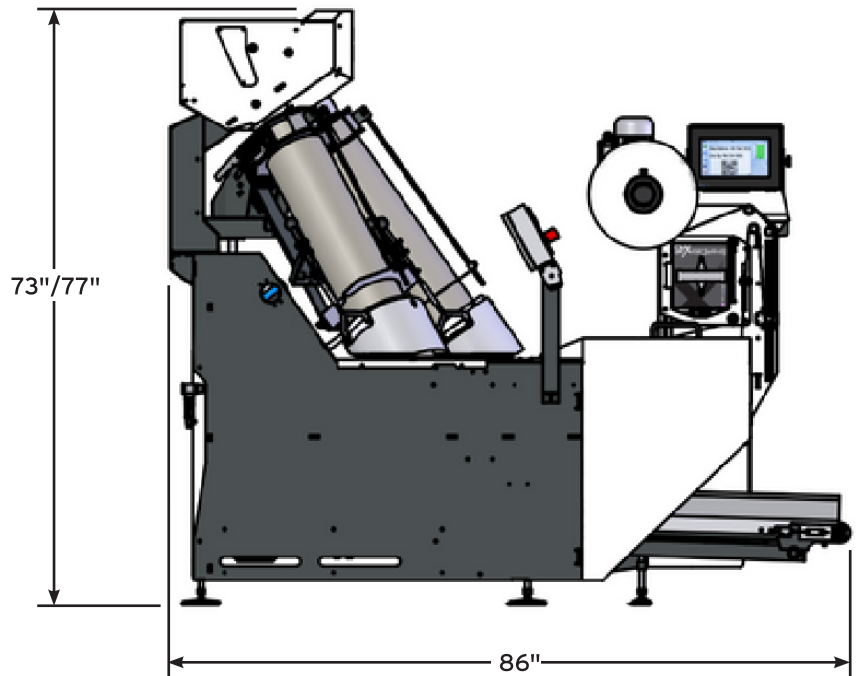
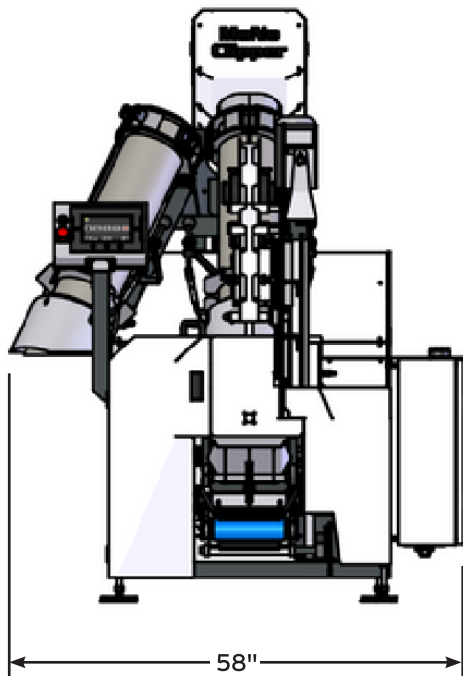
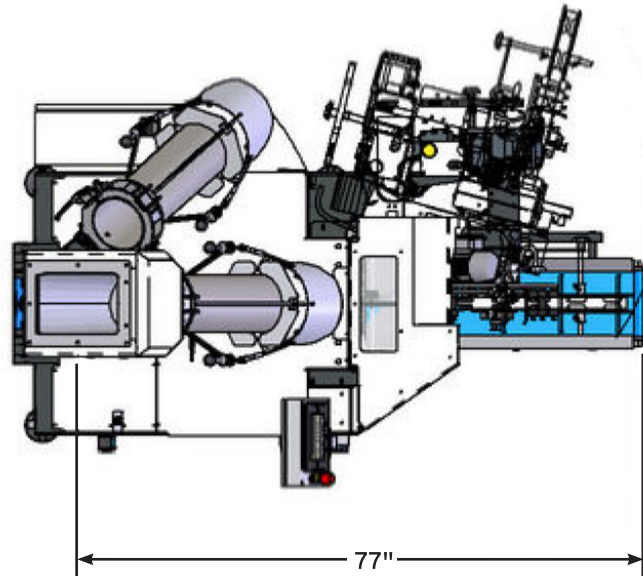

* Depends on product, infeed and discharge system.
** Actual air consumption will increase based on the chosen discharge system(s).
Measurements are rounded off to the nearest inch.