

M10i Ds

The Volmpack M10i Ds stainless steel weigher handles smaller produce at high speeds with great accuracy. With its small footprint, specially designed lanes, and buckets for smaller produce, along with its easy-to-remove parts for quick cleaning and maintenance, this weigher is great for any type of small produce. The M10i Ds also offers a packing range from 1/2 to 5 pounds at rates up to 55 bags per minute, which is excellent for many consumer pack styles.



FEATURES

- 10 bucket scales to weigh a variety of produce types
- The touchscreen computer scans the weights of all the buckets and chooses the best combination to provide the most accurate weight
- The 10 dosing and weigher buckets are designed for quick removal for minimal downtime for cleaning and maintenance
- Robust and stable frame with vibration isolation
- Operators can save packing styles in the user-friendly program for quick and easy changeovers
- Newly designed vibrating lanes for quick transportation of product to the buckets
- Built-in router for remote assistance
- All product contact points are either stainless steel or plastic

DISCHARGE OPTIONS

- Single Belt Discharge
- Dual Belt Discharge
- Center Discharge System

PARTNER OPTIONS

Wicket Baggers
 Pouch Bagger
 Rollstock Poly Bagger
 Rollstock Pouch Bagger
 VFFS Bagger

PACKAGE SIZE RANGE

1/2 to 5 pounds

CAPACITY / RATE

- 1/2 pound up to 55 packages per minute*
- 5 pounds up to 50 packages per minute*

AIR CONSUMPTION

5 CFM**

POWER

230 Volt, 3 Phase and Ground

MOST COMMON PRODUCTS

- Creamer Potatoes
- Shallot
- Baby Carrots
- Citrus
- Garlic

Custom testing available for any product.

* Depends on product, infeed and discharge system.

** Actual air consumption will increase based on discharge system(s) chosen.

M10i Ds

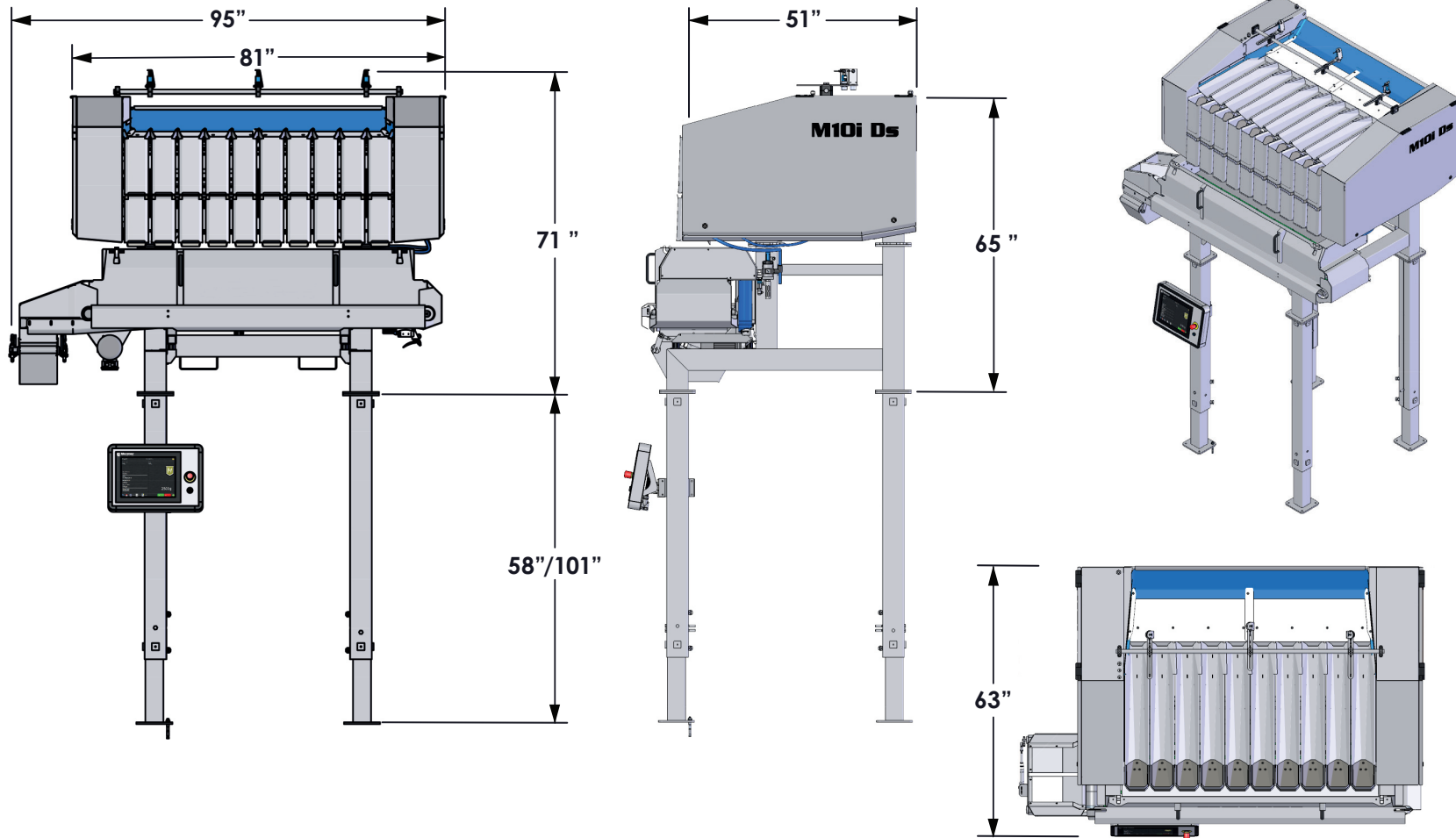

Measurements are rounded off to the nearest inch.