

## VST 30 PALLETIZER

This palletizer is designed to offer a high level of stacking performance with minimal manual labor. Its sturdy design results in a very low maintenance interval.

It can reach a capacity of 22 bags per minute. The manipulator positions your product with the utmost accuracy on the formation slides, allowing for the overlapping of bags.

The formation slides are an indispensable feature to ensure a high capacity as well as great stability. The automatic pallet in-feed ensures an automated process which saves on labor costs.

The user friendly controls are very intuitive. The free-programmable controls offer a setup that meets all of your requirements. Your settings can be changed and stored in the controls.



### FEATURES

- Capacity of up to 22 bags per minute
- Automatic pallet in-feed & out-feed system with wrapper
- Stacking patterns are free-programmable
- Enclosed four-sided stacking chamber
- Touchscreen for easy operation
- Standard LAN connectivity for remote access

### SPECIFICATIONS

- Pallet Sizes: Any pallet up to 5'3" (1600 mm)
- Maximum stacking height of 8'2" (2500mm) including pallet
- Air Consumption varies based on options chosen
- Power: 480 Volt, 3 Phase, Ground, 60 Hz

### OPTIONS

- Enclosed stacking console
- Dual purpose manipulator for handling both bags and cartons
- Electrical adjustable stacking collar

### BAG & CARTON SPECIFICATIONS

MANIPULATOR	ONE	TWO	THREE	CARTON
MINIMUM WEIGHT	11lbs/5kg	55lbs/25kg	22lbs/10kg	2.2lbs/1kg
MAXIMUM WEIGHT	55lbs/25kg	55lbs/25kg	110lbs/50kg	55lbs/25kg
WIDTH	18.1in/460mm	20.9in/530mm	23.2in/590mm	15.8in/400mm
LENGTH	30.3in/770mm	30.3in/770mm	34.7in/880mm	23.6in/600mm

# VST 30 PALLETIZER

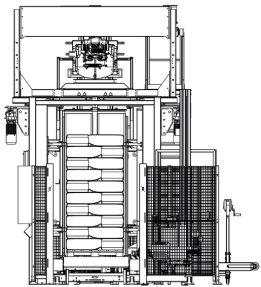
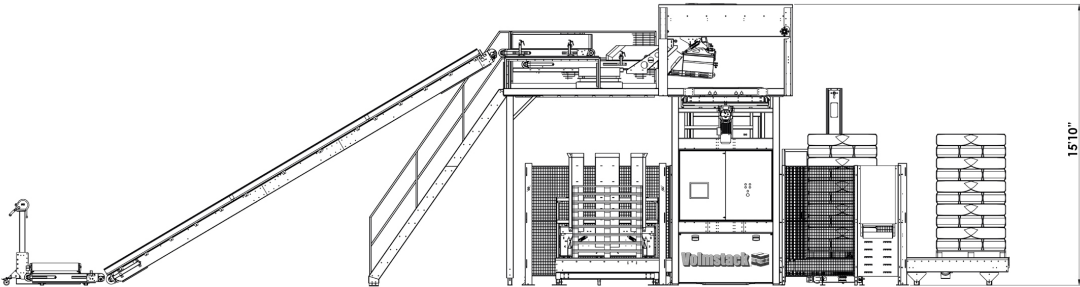
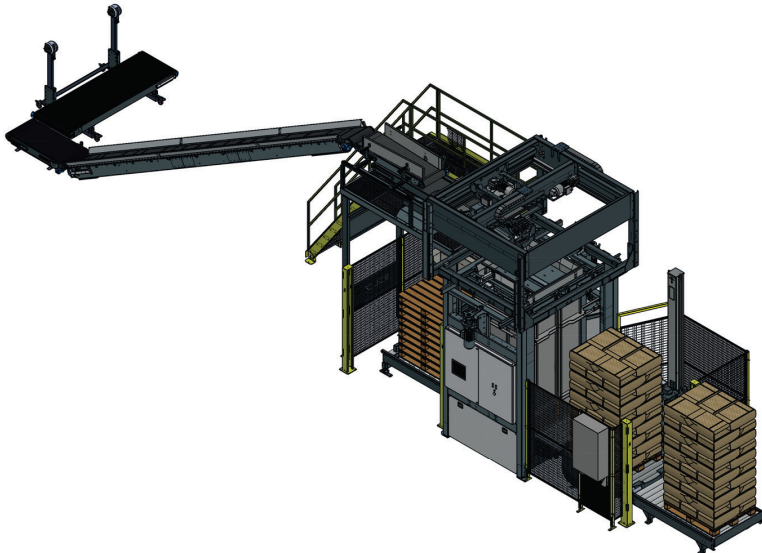
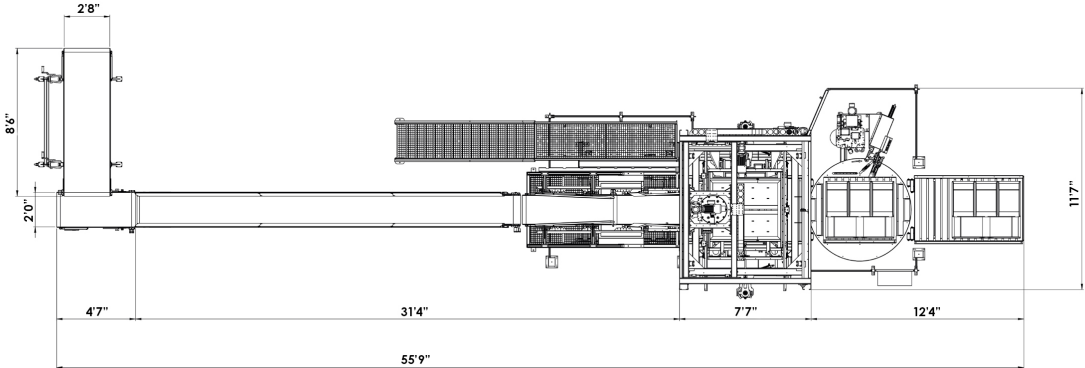

Measurements are rounded off to the nearest inch.