

MD16

The MD16 is the second largest weigher in the Volmpack lineup. It can fill up to four baggers at once and can be purchased with dosing buckets to increase speeds even further. The MD16 also offers a packing range from 1 to 50 pounds at rates up to 75 bags per minute and 80 bags per minute with dosing buckets. The 16 buckets also let the operator choose between three modes (Speed Mode, Accuracy Mode and Rolling Speed/Accuracy Mode).



FEATURES

- Two rows of eight wide bucket scales to weigh a variety of produce types
- High speed computer scans the weights available in all 16 buckets and chooses the best combination to provide the most accurate weight
- Operator can choose between Speed Mode, Accuracy Mode, and Rolling Speed/ Accuracy Mode for their preferred output
- Strong, stable frame with vibration isolation
- Touchscreen computer
- Two computers for performing diagnostics or maintenance while also operating the weigher
- Operators can save packing styles in a user-friendly program for quick and easy changeovers
- Optional belts available versus vibrating lanes
- Optional router for remote assistance
- All product contact points are either stainless steel or plastic
- Service up to four packing machines at once

DISCHARGE OPTIONS

- Dosing Buckets
- Butterfly Divider Discharge
- Single Discharge Belt
- Center Discharge Belt
- Quad V3 (Dual Discharge Belt w/ Divider Flaps)
- Butterfly Divider Discharge w/ Pintle Belts
- Combination Bucket
- 2-Way Holding Bucket

PARTNER OPTIONS

- Dual Wicket Bagger
- Pouch Bagger
- Carousel
- Clipper
- SemiPack
- AutoPack / AutoPack HS
- DLM Clamshell Filler
- Rollstock Pouch Bagger
- Rollstock Poly Bagger
- AutoMesh
- AutoMesh Plus
- Carton Filler
- Vertical Form, Fill & Seal

PACKAGE SIZE RANGE

1 to 50 pounds

CAPACITY / RATE

- 1 to 3 pounds up to 80 bags per minute*
- 5 pounds up to 75 bags per minute*
- 10 pounds up to 56 bags per minute*
- 20 pounds up to 30 bags per minute*
- 50 pounds up to 20 bags per minute*

AIR CONSUMPTION

8 CFM**

POWER

230 Volt, 3 Phase and Ground

MOST COMMON PRODUCTS

- Potatoes
- Onions
- Citrus Fruits
- Brussels Sprouts

Custom testing available for any product.

* Depends on product, infeed, and discharge system.

** Actual air consumption will increase based on discharge system(s) chosen.

MD16

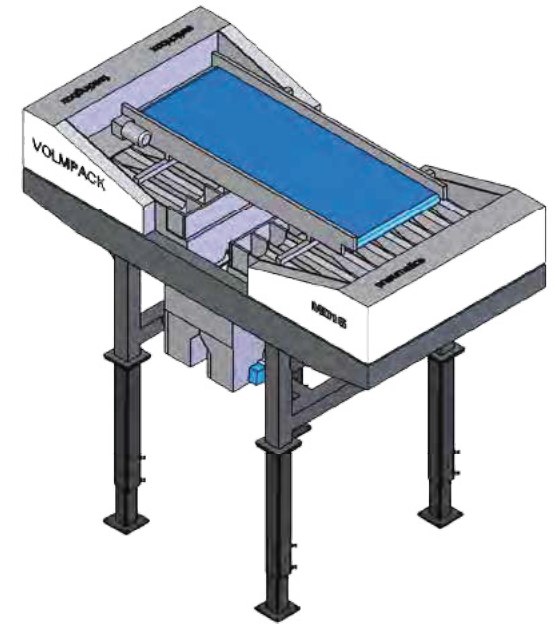
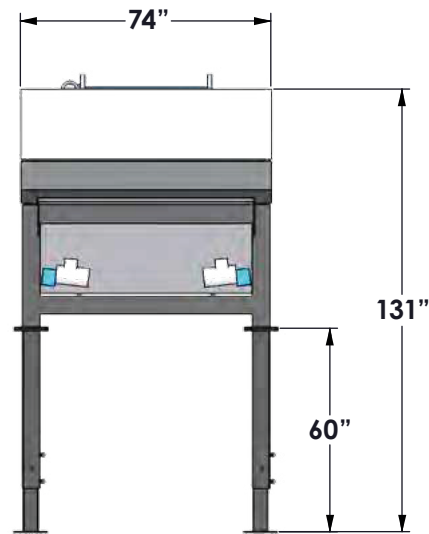
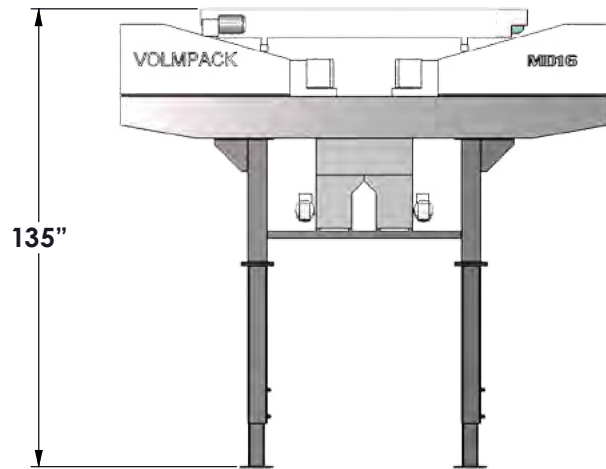
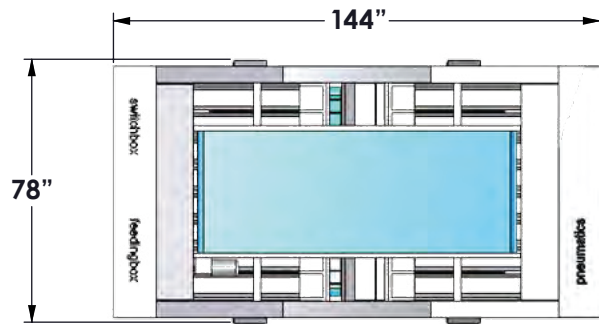

Measurements are rounded off to the nearest inch.