

M2 XXL

The M2 XXL weigher is a great system for packaging lines between 10 and 50 pounds. This multi-lane weigher allows for accurate weights and fast production speeds while keeping costs down. The three vibrating lanes dedicated to each bucket are capable of moving a large volume of product into the buckets. The final weight is handled by a one lane discharge that can send to two sides of the weigher.



FEATURES

- Low cost, high speed system
- Two large weighing buckets with capacities up to 50 pounds
- Both weighing buckets equipped with three vibrating lanes
- Touchscreen operation

DISCHARGE OPTIONS

Single Discharge Belt

PARTNER OPTIONS

- Carton Filler
- SemiPack
- AutoPack / AutoPack HS
- Rollstock Poly Bagger
- Auto Mesh
- Auto Mesh Plus

PACKAGE SIZE RANGE

10 to 50 pounds

CAPACITY / RATE

- 10 pounds up to 24 bags per minute*
- 25 pounds up to 16 bags per minute*
- 50 pounds up to 14 bags per minute*

AIR CONSUMPTION

4 CFM**

POWER

230 Volt, 3 Phase and Ground

MOST COMMON PRODUCTS

- Potatoes
- Onions
- Citrus Fruits
- Brussels Sprouts
- Carrots

Custom testing available for any product.

* Depends on product, infeed, and discharge system.

** Actual air consumption will increase based on discharge system(s) chosen.

M2 XXL

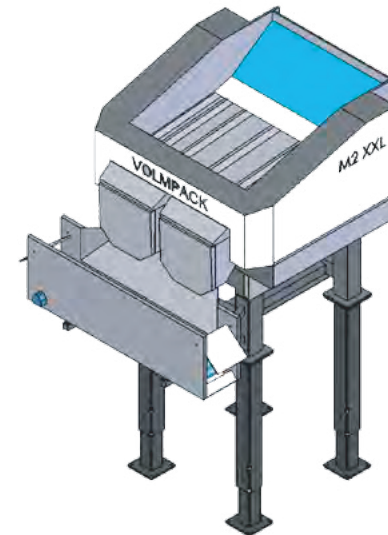
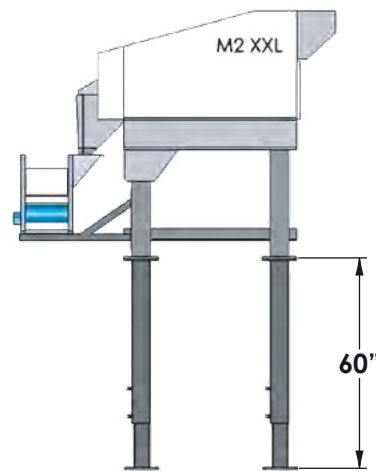
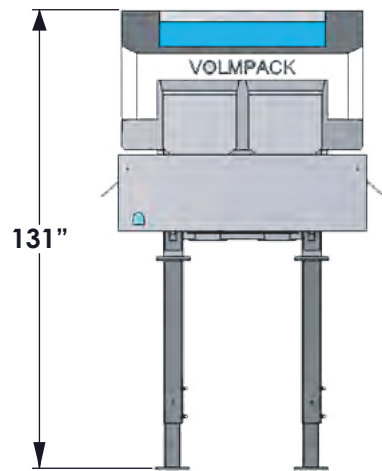
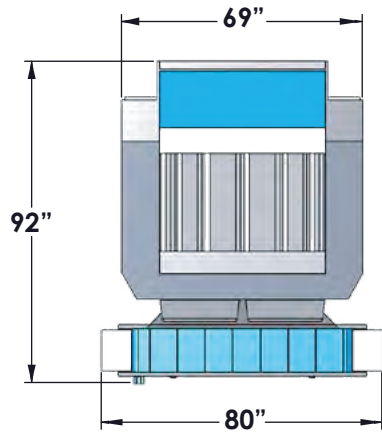

Measurements are rounded off to the nearest inch.