

## M12 Ca

The M12 Ca has 12 extra-long weighing buckets specifically designed for long products like carrots and parsnips. It is the go-to weigher for large carrot packers. The M12 Ca also offers a packing range from 1 to 50 pounds at rates up to 55 bags per minute, which makes it a high speed addition in any long produce application.

### FEATURES

- 12 long bucket scales to weigh long products effectively
- High speed computer scans the weights in all 12 buckets and chooses the best combination to provide the most accurate weight
- Strong, stable frame with vibration isolation
- Touchscreen computer
- Two computers for performing diagnostics or maintenance while also operating the weigher
- Operators can save packing styles in the user-friendly program for quick and easy changeovers
- Optional belts instead of standard vibrating lanes
- Optional router for remote assistance
- All product contact points are either stainless steel or plastic

### DISCHARGE OPTIONS

- Stainless Steel, Dual Discharge Belt
- Funnel
- Combination Bucket
- Intermediate Bucket

### PARTNER OPTIONS

Rollstock Poly Bagger  
Dual Wicket Bagger



### PACKAGE SIZE RANGE

1 to 50 pounds

### CAPACITY / RATE

- 1 pounds up to 55 packages per minute\*
- 5 pounds up to 50 packages per minute\*
- 10 pounds up to 40 packages per minute\*
- 20 pounds up to 20 packages per minute\*

### AIR CONSUMPTION

6 CFM\*\*

### POWER

230 Volt, 3 Phase and Ground

### MOST COMMON PRODUCTS

- Carrots
- Parsnips

Custom testing available for any product.

\* Depends on product, infeed, and discharge system.

\*\* Actual air consumption will increase based on discharge system(s) chosen.

# M12 CA

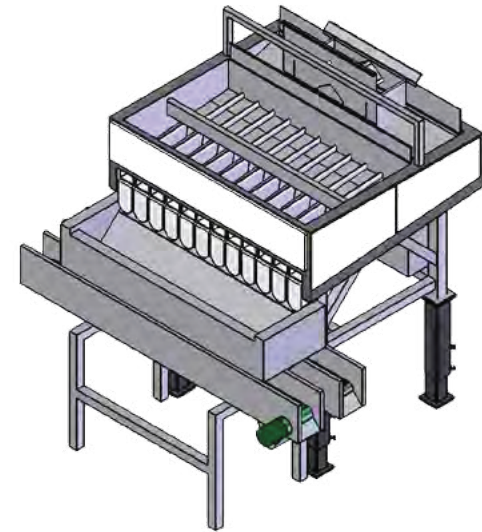
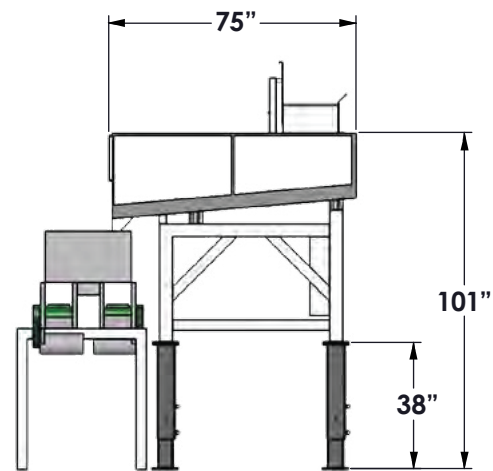
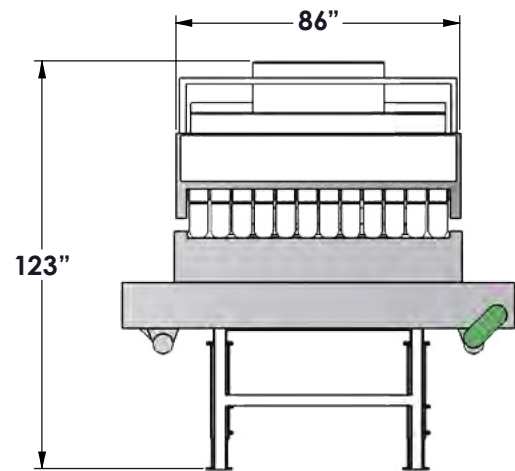
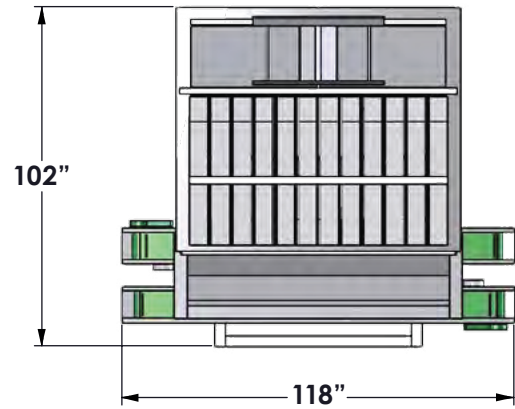

Measurements are rounded off to the nearest inch.