

M10 Ca

The M10 Ca was specifically designed for long products such as carrots and parsnips. It is the go-to weigher for small and medium carrot packers. The M10 Ca also offers a packing range from 5 to 50 pounds at rates up to 28 bags per minute, which makes it a versatile addition to any carrot packing facility.

FEATURES

- 10 long bucket scales to weigh long products effectively
- High speed computer scans the weights in all 10 buckets and chooses the best combination to provide the most accurate weight
- Strong, stable frame with vibration isolation
- Touchscreen computer
- Two computers for performing diagnostics or maintenance while also operating the weigher
- Operators can save packing style in the user-friendly program for quick and easy changeovers
- Optional belts instead of standard vibrating lanes
- Optional router for remote assistance
- All product contact points are either stainless steel or plastic

DISCHARGE OPTIONS

- Stainless Steel, Single Discharge Belt
- Stainless Steel, Dual Discharge Belt
- Combination Bucket
- Intermediate Bucket

PARTNER OPTIONS

- Single Wicket Bagger
- Rollstock Poly Bagger



PACKAGE SIZE RANGE

5 to 50 pounds

CAPACITY / RATE

- 5 pounds up to 28 bags per minute*
- 10 pounds up to 25 bags per minute*
- 20 pounds up to 20 bags per minute*

AIR CONSUMPTION

5 CFM**

POWER

230 Volt, 3 Phase and Ground

MOST COMMON PRODUCTS

- Carrots
- Parsnips

Custom testing available for any product.

* Depends on product, infeed, and discharge system.

** Actual air consumption will increase based on discharge system(s) chosen.

M10 CA

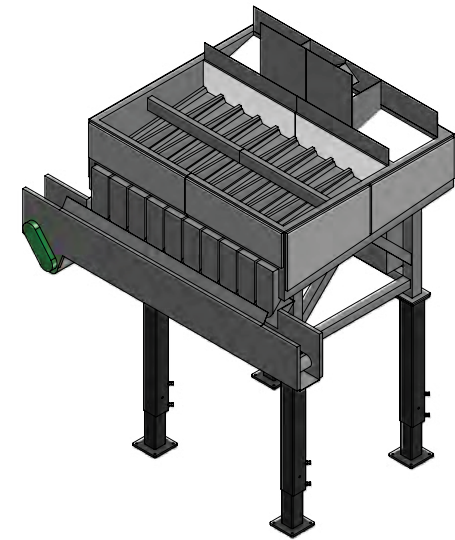
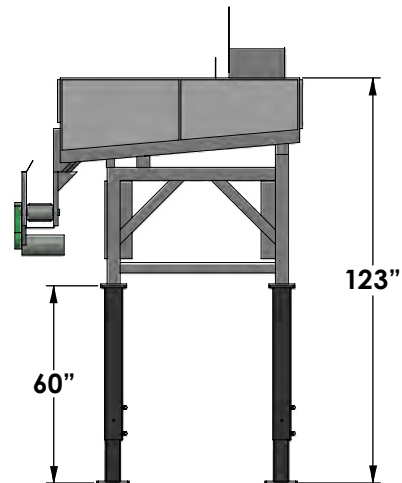
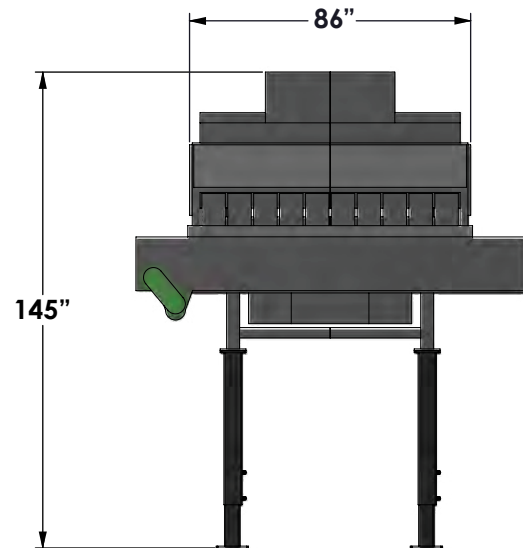
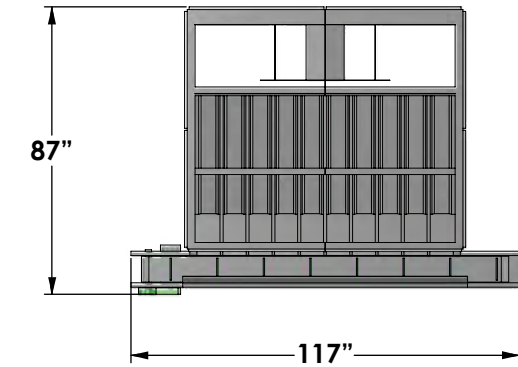

Measurements are rounded off to the nearest inch.