

## CHECKWEIGHER

The Volmpack Checkweigher is specifically designed for the accurate weighing of fresh produce packages. Using the newest technology, today's Volmpack Checkweigher provides the most consistently accurate solution in the market. It's sturdy and steady construction is the key to its accuracy in weighing. It weighs products from 1 to 22 pounds with production rates up to 70 packages per minute.

The Checkweigher is available with three different reject system options, to provide the optimal solution based on your package style, size and weight.

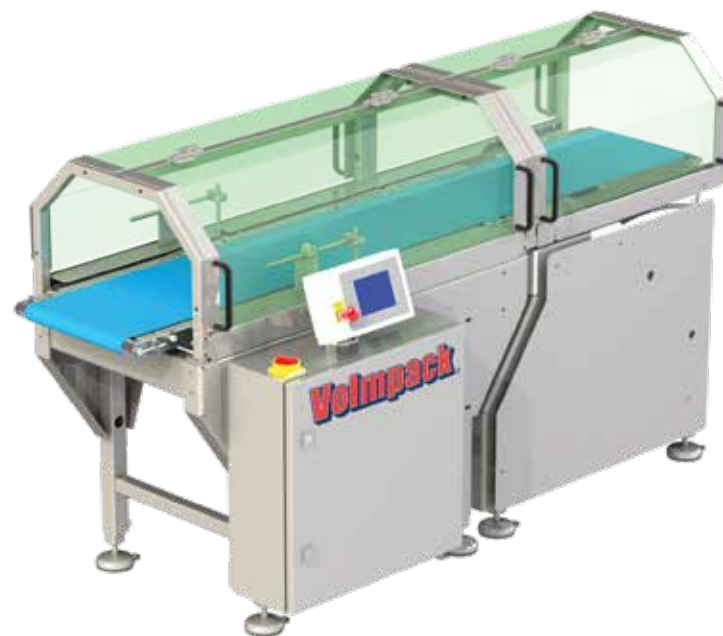

---

### FEATURES

- Strong, stable construction for accuracy and fast weighing
- Two weighing belt lengths available for different package weights
- Remote assistance available via optional router
- Omron HMI display for easy operation

### ADDITIONAL OPTIONS

All Volmpack weighers

### MODEL SPECIFICS

Model 40  
400mm L weighing belt, up to 5.5 lb. pkg

Model 60  
600mm L weighing belt, up to 22 lb. pkg

### PACKAGE SIZE RANGE

1 to 22 pounds

### CAPACITY / RATE

Model 40  
Up to 70 packages per minute\*

Model 60  
Up to 60 packages per minute\*

### AIR CONSUMPTION

11 CFM\*\*

### POWER

230 Volt, 3 phase and ground

### MOST COMMON PRODUCTS

- Potatoes
- Onions
- Citrus Fruits

Custom testing available for any product.

---

\* Depends on product, infeed, and discharge system.

\*\* Actual air consumption will increase based on discharge system(s) chosen.

# CHECKWEIGHER

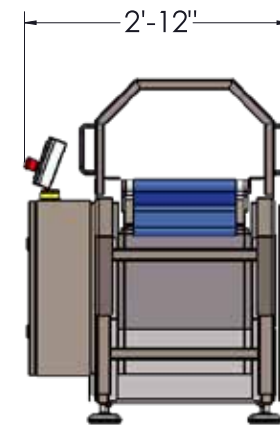
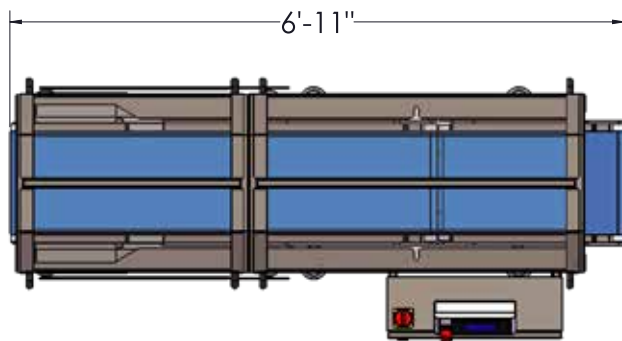
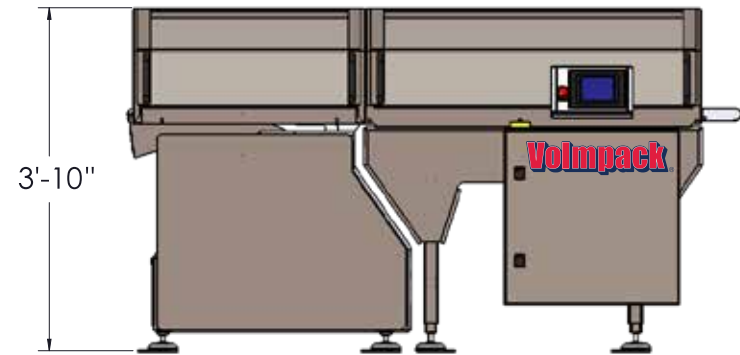
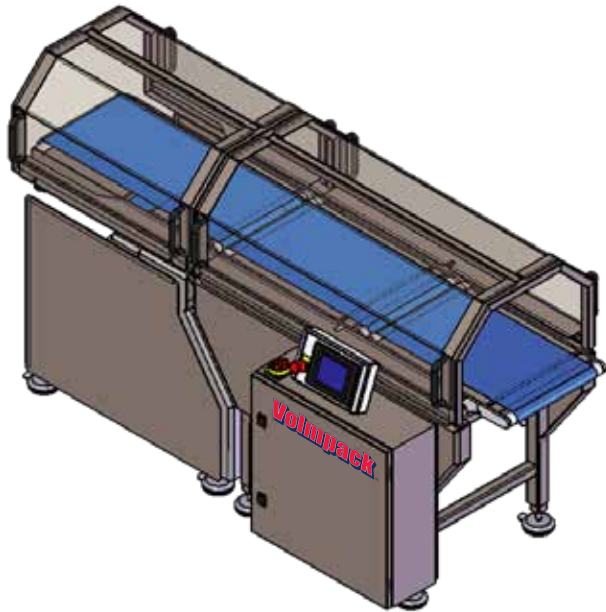

Measurements are rounded off to the nearest inch.