

BD606 CASE PACKER

The Volmpack BD606 Case Packer is a compact, high-speed, fully automated case packing system that can integrate with your existing packing line seamlessly. Using the BD606 touch screen computer, you can change packing layouts easily and you are able to move between different packing lines with little disruption. With this versatility you can have multiple packing configurations to fill trays, crates or boxes. The BD606 can pack up to 50 packages per minute.

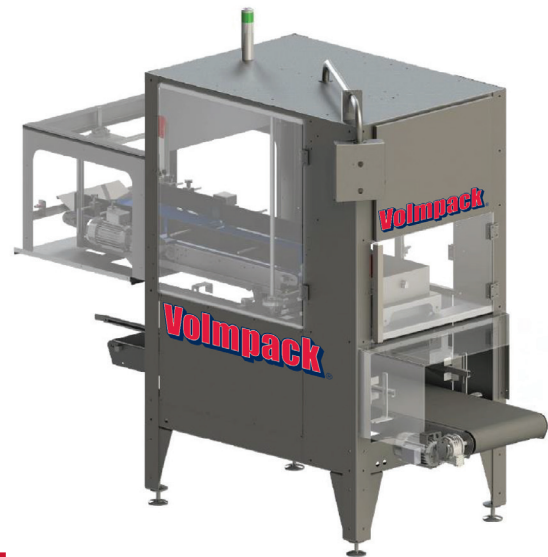

FEATURES

- Touch screen to control all settings and manage product layout
- Stainless Steel construction
- Straightforward and efficient integration with existing packing lines
- Flexibility to move between different packing lines with minimal disruption
- Multiple packing configurations for plastic or corrugated trays, boxes or crates

OPTIONS

- Empty box drag-in from all directions
- Full box push-out to all directions
- Internal lift for secure drop of products

PACKAGE SIZE/WEIGHT RANGE

- Min 3.9"L x 3.9"W x 2.0"H Max. 13.8"L x 11.8"W x 7.9"H
- 3 ounces to 10 pounds

CASE SIZE/WEIGHT RANGE

- Min 15.8"L x 11.8"W x 3.5"H Max. 23.6"L x 15.8"W x 16.5"H
- 1 to 55 pounds

CAPACITY/RATE

- Up to 50 packages per minute*

AIR CONSUMPTION

- Actual air consumption depends on options chosen

POWER

- 230 Volt, 3 phase and ground

PACKAGING STYLES



Block Bottom



Carry Bag



Pillow Pack



Pouch Bag



Net Bag



Wicketed Bag

*Depends on product, in-feed and packing pattern

BD606 CASE PACKER

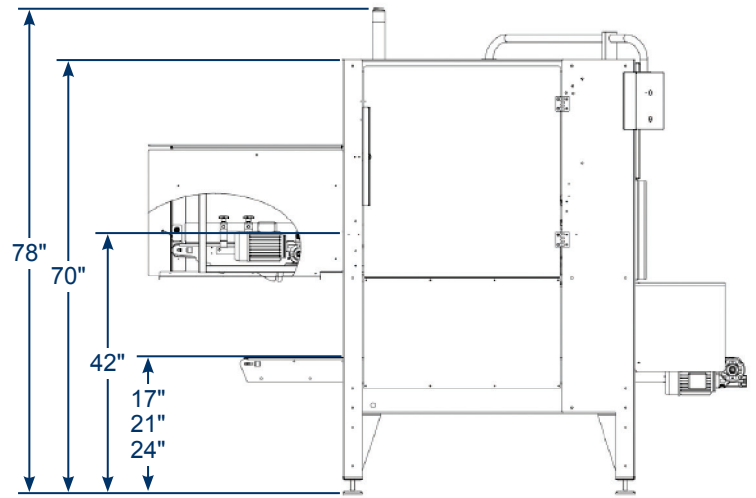
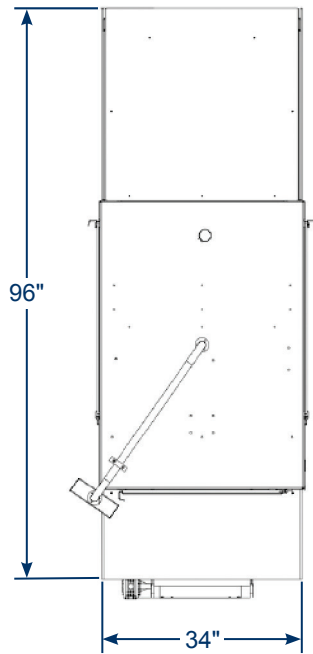

Measurements are rounded to the nearest inch

TRAY & BOX OPTIONS



Die-Cut Tray with Flaps



RPC (Reusable Plastic Container)



Die-Cut Open Tray

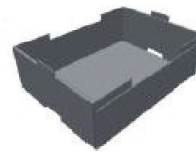

RSC (Regular Slotted Container)



Corrugated Box

PACKING PATTERNS

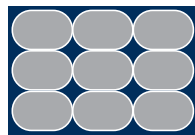
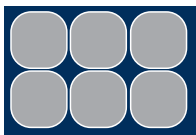
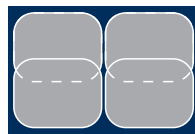

Additional packing patterns available upon request

CASE PACKERS QUICK REFERENCE GUIDE

BD606 CASE PACKER

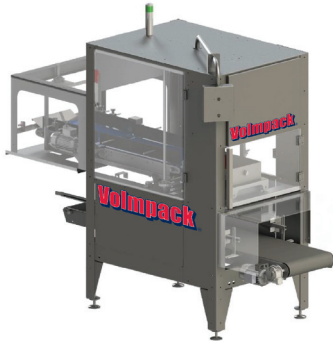

PC121 CASE PACKER

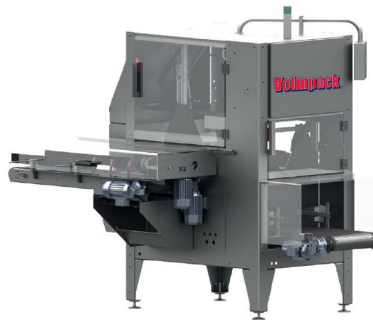

TV80 CASE PACKER

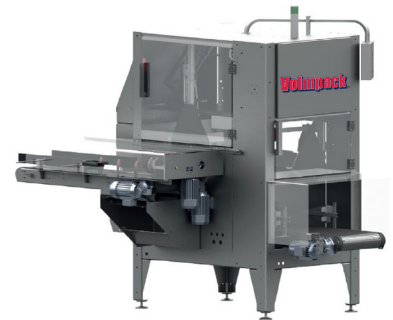

BD606 -15 CASE PACKER



PDS90 CASE PACKER



DE-STACKER



SPECIFICATIONS	BD606	BD606-15	PC121	PDS90	TV80	DE-STACKER
Capacity	50 drops/min	40 drops/min	10 layers/min	8 layers/min	10 layers/min	12 boxes/min
Packaging Method	Cradle	Sliding	Drop	Drop	Vacuum	De-stack
When to Use	Bags that can handle the drop and with simple patterns	Heavy bags at low speed, with drop point in the middle of the box	Soft products that must be placed gently in a box	When the box has stacking flaps	If there is no space in the box to fit a tool around the products, then vacuum can work on the top	Boxes stacked on top of each other
When Not to Use	Products that are tightly packed in nets, as they will have a tendency to stack up	Products that should be packed in patterns or is very tight packed	If the product is too soft to be pushed or too skewed to make a complete pattern	If the box is above 5" tall	If the punnet has air holes or the product might get damaged from the vacuum	Nesting trays
Product Weight	3oz to 10lbs	10lbs to 30lbs	3oz to 3.3lbs	3oz to 3.3lbs	3oz to 3.3lbs	N/A
Minimum Packaging Size	3¾"x 3¾"x 2"	3¾"x 3¾"x 2"	3¾"x 3¾"x 2"	3¾"x 3¾"x 2"	3¾"x 3¾"x 2"	N/A
Maximum Packaging Size	14"x 12"x 8"	24"x 16"x 7½"	12"x 12"x 5"	12"x 12"x 5"	12"x 12"x 5"	N/A
Maximum Case Weight	50lbs	65lbs	50lbs	50lbs	50lbs	Column of 65lbs
Minimum Case Size	16"x 12"x 3½"	16"x 12"x 3½"	16"x 12"x 3½"	16"x 12"x 3½"	16"x 12"x 3½"	16"x 12"x 3½"
Maximum Case Size	24"x 16"x 16½"	24"x 16"x 16½"	24"x 16"x 10"	24"x 16"x 10"	24"x 16"x 10"	24"x 16"x 16"
Air Consumption	1.25cfm @ 90psi	1.25cfm @ 90psi	3cfm @ 90psi	3.5cfm @ 90psi	3.5cfm @ 90psi*	3.5cfm @ 90psi*
Power	230VAC 3PH 60hz	230VAC 3PH 60hz	230VAC 3PH 60hz	230VAC 3PH 60hz	230VAC 3PH 60hz	230VAC 3PH 60hz

* Depending on vacuum pressure

CASE PACKERS QUICK REFERENCE GUIDE

PACKAGING STYLES	BD606	BD606-15	PC121	PDS90	TV80	DE-STACKER
Block Bottom	✓					
Carry Bag	✓					
Clamshell			✓	✓	✓	
Flow Wrapped			✓	✓		
Mesh Bag		✓				
Net Bag	✓					
Net Wrapped			✓	✓		
Pillow Pack	✓			✓		
Pouch Bag	✓					
Stretch Wrapped			✓	✓		
Top Sealed					✓	
Wicketed Bag	✓	✓				



✓ Block Bottom



✓ Clamshell



✓ Mesh Bag



✓ Net Wrapped



✓ Pouch Bag



✓ Top Sealed



✓ Carry Bag



✓ Flow Wrapped



✓ Net Bag



✓ Pillow Pack



✓ Stretch Wrapped



✓ Wicketed Bag

TRAY & BOX OPTIONS	BD606	BD606-15	PC121	PDS90	TV80	DE-STACKER
Die-Cut Tray w/Flaps	✓	✓		✓	✓	✓
RPC	✓	✓	✓	✓	✓	✓
Die-Cut Open Tray	✓	✓	✓	✓	✓	✓
RSC	✓	✓	✓	✓	✓	✓
Corrugated Box	✓	✓			✓	

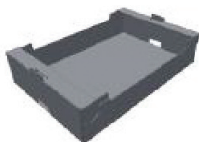

✓ Die-Cut Tray with Flaps



✓ RPC (Reusable Plastic Container)



✓ Die-Cut Open Tray

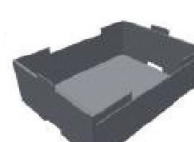

✓ RSC (Regular Slotted Container)



✓ Corrugated Box