

M12i FR

The M12i FR stainless steel weigher with dosing buckets is designed with frozen meats, fish & vegetables in mind. It is equipped with easy to remove V-shaped buckets that are designed for fast cleaning and less down time. The V-shaped buckets allow for gentler product handling. The M12i FR is optimized for high capacity with small weights. With a low drop, the weight will be directly applied to the discharge belt, giving you gentler handling of your product.

FEATURES

- 12 V-shaped bucket scales to weigh a variety of products and handle them gently
- High speed computer scans the weights available in all 12 buckets and chooses the best combination to provide the most accurate weight
- Strong, stable stainless steel construction with vibration isolation
- Touchscreen computer
- Two computers for performing diagnostics or maintenance while also operating the weigher
- Operators can save packing styles in a user-friendly program for quick and easy changeovers
- Standard router for remote assistance
- All product contact points are either stainless steel or plastic

DISCHARGE OPTIONS

- Single Discharge Belt
- Dual Discharge Belt

PARTNER OPTIONS

DLM Clamshell
 Kangaroo Bagger
 Kangaroo 2 Bagger
 Vertical Form, Fill, & Seal



TECH SPECS.

PACKAGE SIZE RANGE

1 to 50 pounds

AIR CONSUMPTION

6 CFM**

POWER

230 Volt, 3 Phase and Ground

** Actual air consumption will increase based on discharge system(s) chosen.

MOST COMMON PRODUCTS

- Frozen Meat
- Frozen Fish
- Frozen Vegetables
- Sliced Onions, Potatoes & Vegetables

Custom testing available for any product.

CUSTOM PACKAGING SOLUTIONS CUSTOM PACKAGING SOLUTIONS CUSTOM PACKAGING SOLUTIONS CUSTOM PACKAGING SOLUTIONS CUSTOM PACKAGING SOLUTIONS



M12i FR



DIMENSIONS

L 113in x W 106in x H 128in**

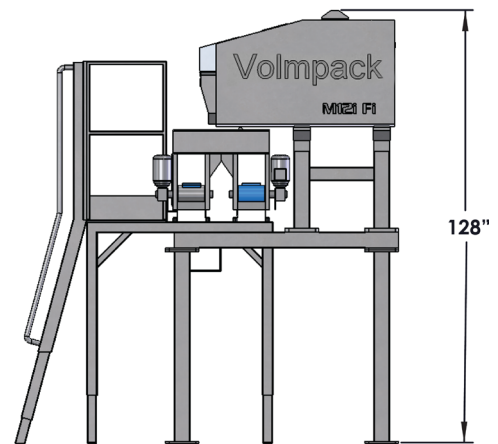
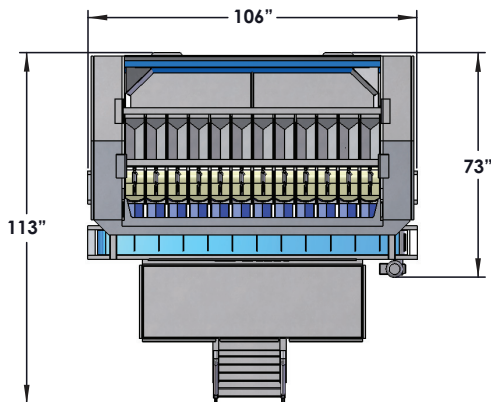
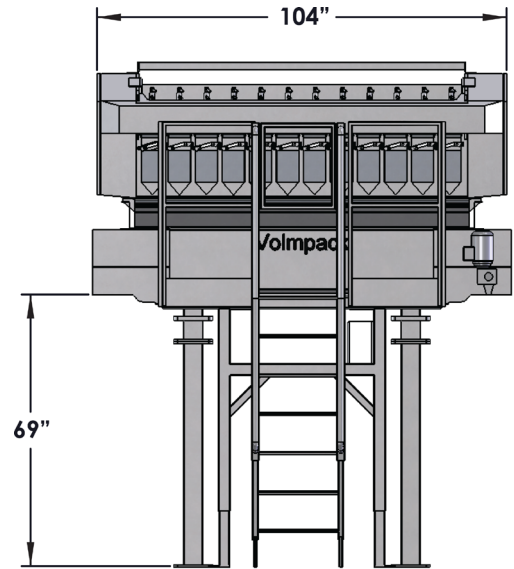
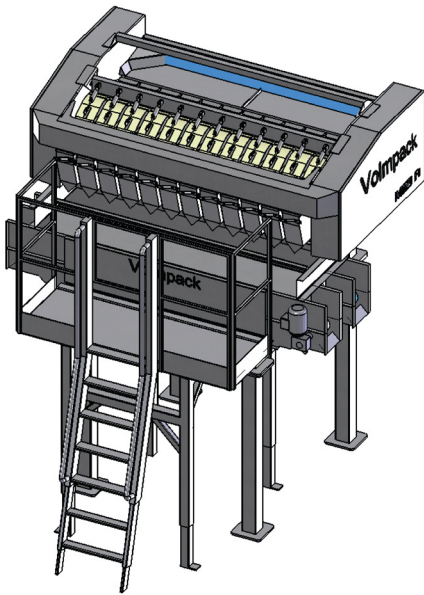

*** Measurements rounded up to the nearest inch



If you need it, or can dream it – it's likely we can make it happen.

Our Custom Packaging Solutions Team works with customers to create custom solutions that meet a wide range of packaging needs.