

POUCH BAGGER

The Pouch Bagger is a single pouch bagging machine which easily bags product in common, pre-made pouch style bags. Optional sealing units can be added to automate the sealing process. Options include a heat sealer and/or zip lock closer. The Pouch Bagger allows facilities to move away from costly and labor-intensive manual pouch bagging to affordable, high-speed automation. At up to 20 bags per minute, the Pouch Bagger can help keep up with consumer demands.

FEATURES

- Pouches can include multiple handle styles, tear notches, venting options, various films and die cut corners
- Interfaces with many fillers
- Robust, strong frame
- Requires little floor space
- Easy access for service and maintenance
- User-friendly program allows operators to create many set-ups with ease
- Clear doors around the machine for both safety and easy viewing of internal parts of machine
- Optional router for remote assistance

ADDITIONAL OPTIONS

- Produce Settler for reliable sealing
- Soft-Handling version available

PARTNER EQUIPMENT

- M8
- M10
- MD12
- M12 V
- M12i V
- M16i V
- MD16
- MD16 D
- MD20D
- M2i V



PACKAGE SIZE RANGE

Up to 20 pounds

CAPACITY / RATE

Up to 20 pouches per minute*

AIR CONSUMPTION

20 CFM**

POWER

230 Volt, a 3 Phase and Ground

* Depends on product, infeed, and discharge system.

** Actual air consumption will increase based on discharge system(s) chosen.

POUCH BAGGER

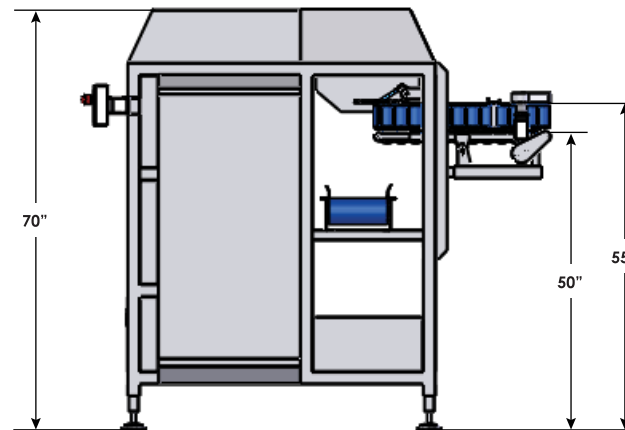
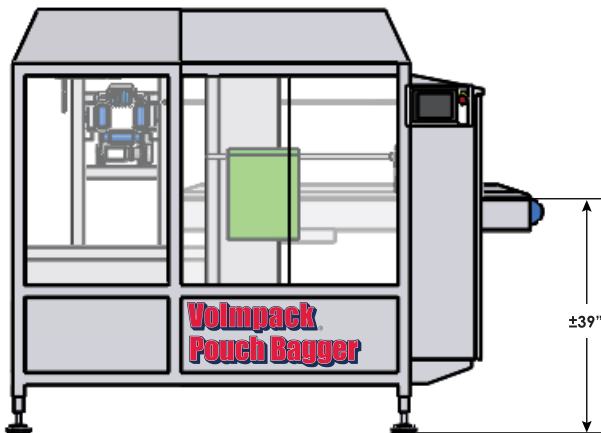
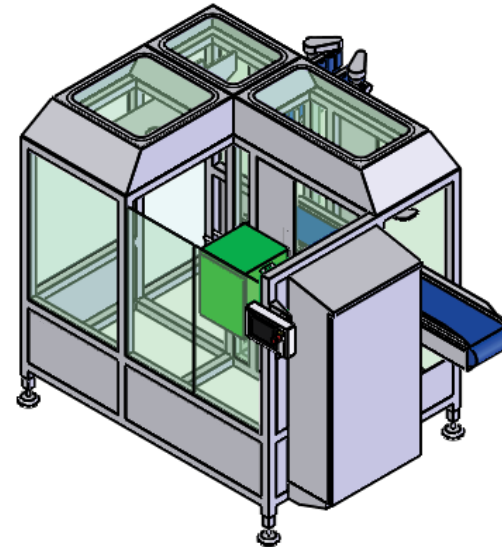
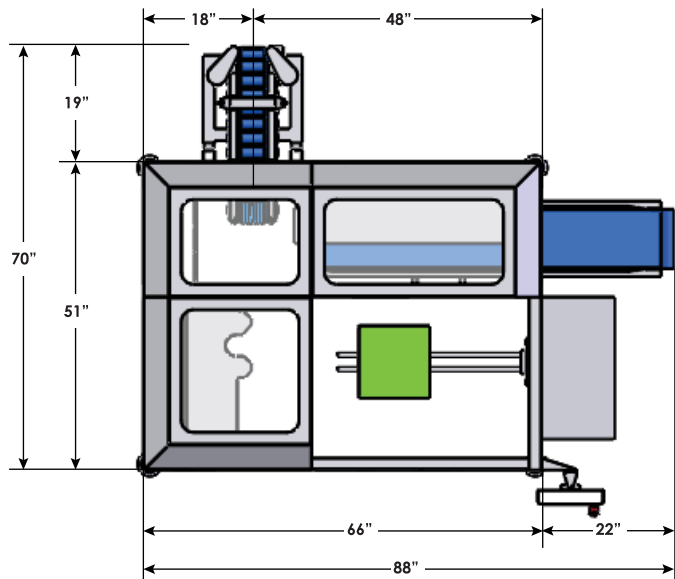

Measurements are rounded off to the nearest inch.