



THE BEST FROM EVERY HARVEST

Conveying



# Octal-S Conveyors & Elevators

Efficiently transport produce from one location to another.  
Low-maintenance slat beds with modular design.

Suitable for all produce types.

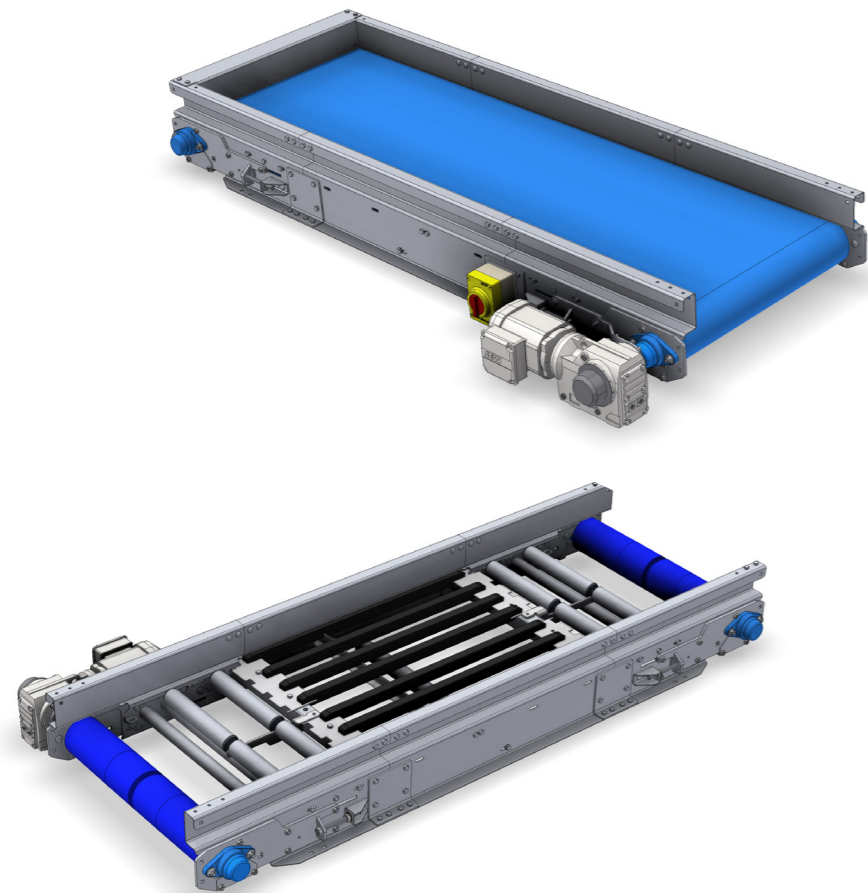

Our brand new Octal-S Conveyors & Elevators transport produce efficiently to different parts of your line.

Produce is fed on to the conveyor or elevator and is transported in the direction of belt motion. The belt runs on a low-maintenance slat bed for a smooth and even motion. Return drums help with belt tension and also make sure there is no belt slippage.

Conveyors can have produce sweeps included to divide produce flow, if needed. In-feed and out-feed chutes are available.

Elevators have 50mm cleats along the belt so they can transport produce to different heights. A gooseneck can be added for feeding produce gently to the next stage in your line.

## Features and benefits

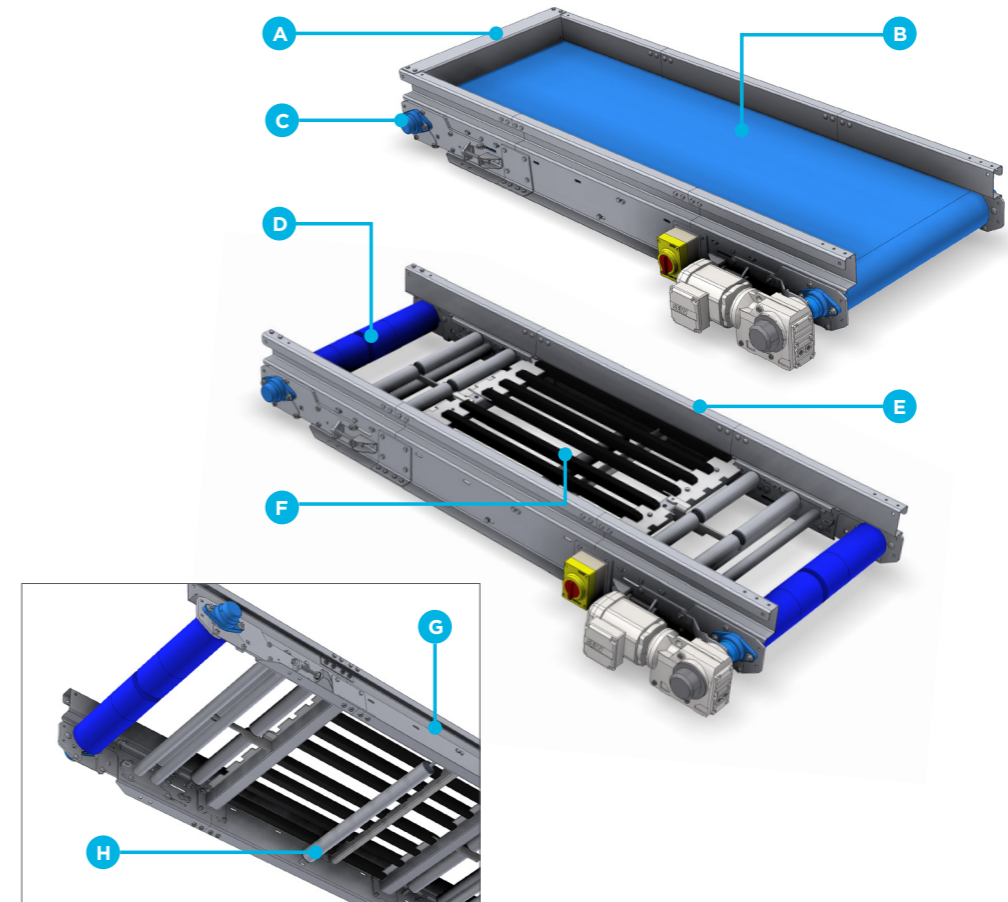

A Backstop\*

B PVC belt

C Fully covered bearings

D Urethane drums

E Fully supported belt edges

F Slat bed

G Modular design

H Seamless return rollers

Prevents produce roll-back

Good quality and long lasting

Safe operation

Longer life than steel drums; no pitting or rust

More grip than steel drums

Safe

Less produce loss or jamming

Very low maintenance

Gives flexibility during installation

Allows for modifications at a later date

Can be supplied flat-packed to save on cost and freight

Smooth operation

Long life

\* Optional

