



THE BEST FROM EVERY HARVEST

Hoppers



Creep Feed Hopper

Receives and conveys produce with a high level of dirt and clods.

Potatoes • Carrots • Parsnips • Swedes • Turnips • Beetroot • Celeriac and more

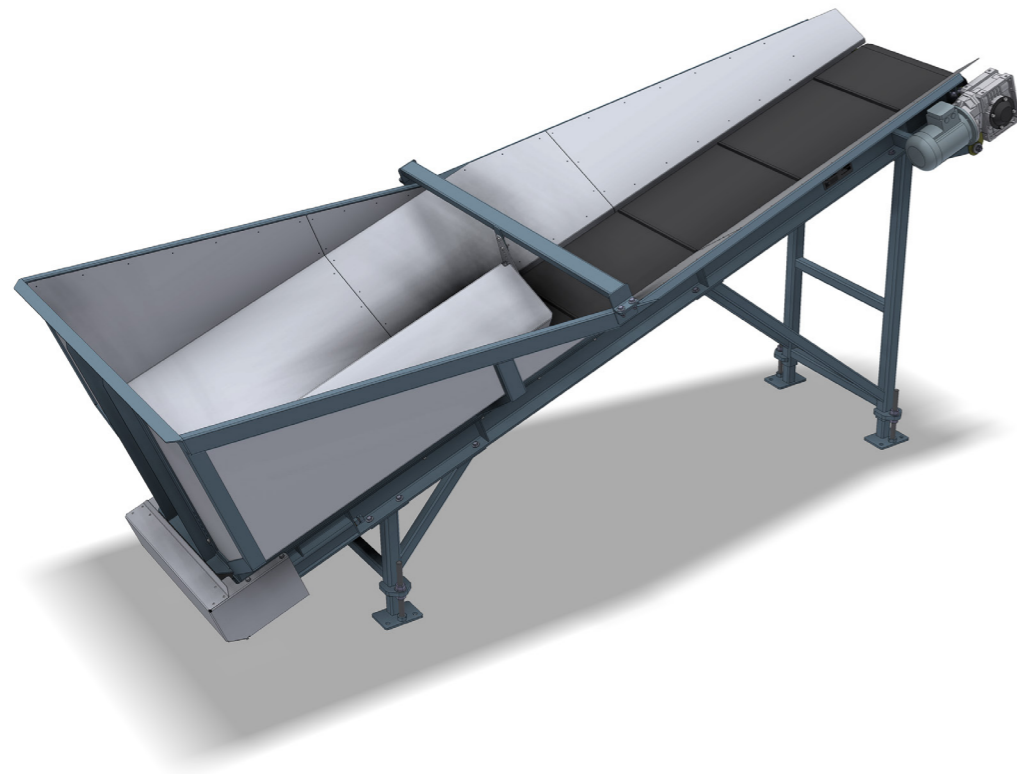

Our Creep Feed Hopper receives wet or dry produce with a high level of dirt and clods (from storage or from the field). It allows for fast unloading and changeover time without starving your line of produce. Provides produce buffering.

Bulk produce is unloaded from a truck or bin tipper straight into the Creep Feed Hopper. Produce enters at the deep 'storage' end.

A conveyor slowly moves produce to the outfeed end. This slow feed provides an even flow of produce to the next stage in your line. When Wyma Electrical Controls are purchased the conveyor speed automatically adjusts to maintain the even flow.

Hopper angle and tank height are chosen to suit your needs. Tank angle can be a maximum of 20°.



Features and benefits



- A Turkey roost
- B Heavy-duty belt
- C Variable speed conveyor
- D Large storage capacity
- E Adjustable feet*
- F Simple, durable tensioning system
- G Stainless steel roller bed**

Maintenance access
Easy to integrate with existing equipment or new processing lines

- Spreads produce across conveyor
- Regulates outfeed rate
- Robust and long lasting
- Changes belt speed for smooth produce flow rate
- Allows feed rate control and soft start to reduce jolting
- Allows up to 20t of produce to be received and stored before it enters your line
- For easy, level installation
- Very low maintenance and easy to adjust
- Less friction
- Long life and low maintenance
- Easy cleaning and maintenance
- Flexible application

* Optional
** Smaller models only. Larger models have a slatted belt with a chain

