

CAROUSEL CBS-6

The Carousel (CBS-6) is the most versatile bagging system that Volm offers. A large number of products and package types can be used with this bagger. This makes the Carousel a useful bagger in many small and medium packing facilities.

As the CBS-6 rotates, bags are manually hung from its 6 jaws. The jaws are triggered automatically when bags are hung. After bags are filled, the Carousel continues to rotate until they are automatically released. Bags can then be closed manually or automatically.



FEATURES

- Vibrating, fiberglass top that receives pre-weighed batches — produce flows through the curved jaws into bags hanging below
- Pneumatic jaws to hold bag securely in place
- Continuous rotation to maintenance high speed packing and reduce required maintenance
- “Easy touch” safety bar ensures a safe working environment — stopping the CBS-6 requires a slight touch anywhere along the safety bar

ADDITIONAL OPTIONS

- Jaw Conversion Kit for Small Bags
- CBS-4 Carousel for filling 25, 50, and 100 pound bags

WEIGHING PARTNERS

- M8
- M10
- M10 XL
- MD12
- M12 V
- MD14 XL
- MD16
- MD16 D
- MD20 D
- M2 XXL
- M2i V

PACKAGE WEIGHT RANGE

1 to 50 pounds

PACKAGE DIMENSIONS

- Min. 20”(508mm) W x 12”(305mm) H
- Max. 26”(660mm) W x 30”(762mm) H

CAPACITY / RATE

Up to 60 bags per minute*

AIR CONSUMPTION

8 CFM**

POWER

230 Volt, 3 Phase and Ground

* Depends on product, infeed, and discharge system

** Actual air consumption will increase based on discharge system(s) chosen

CAROUSEL CBS-6

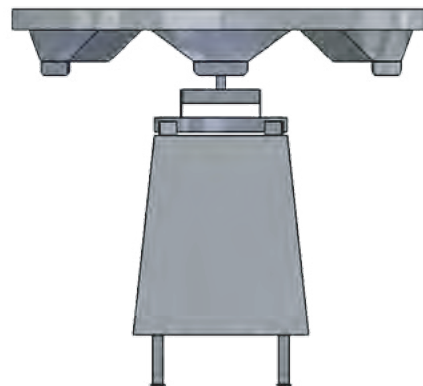
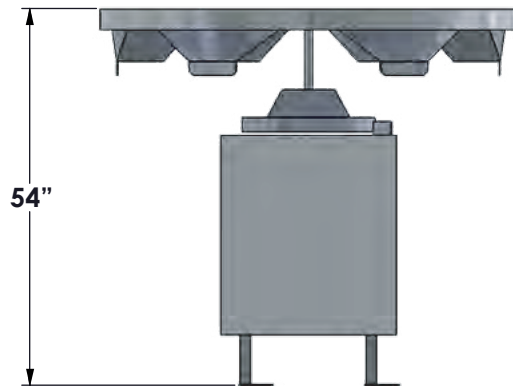
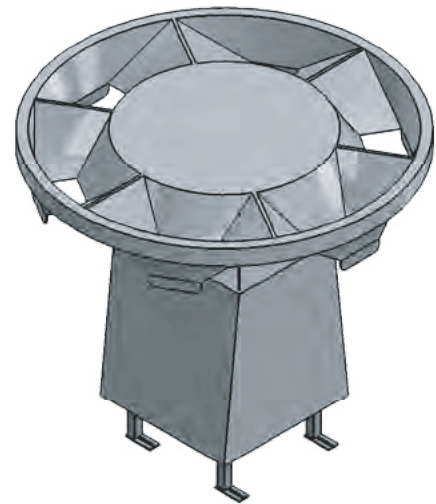
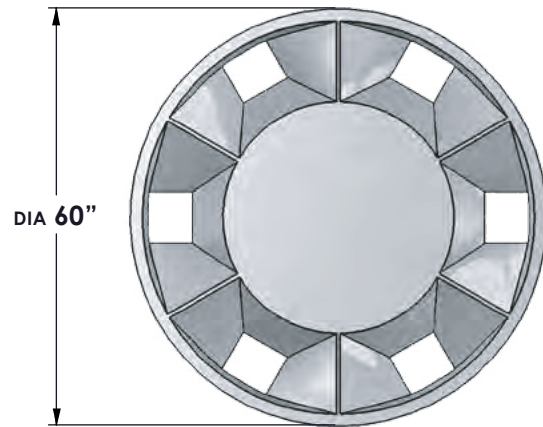

Measurements are rounded off to the nearest inch.